

INSTALLATION INSTRUCTIONS

IMPORTANT: Turn off power before installing or removing connector. Product to be used in accordance with local and national codes.

1. Strip wires 5/8" (15.9 mm).
2. Pre-twisting unnecessary. Hold stripped wires together with ends of insulation even. Lead stranded wires slightly.
3. Align any frayed strands or conductors Fig. 1
4. Firmly push wires into twist-on connector and screw connector clockwise onto wire until tight. Fig. 2
5. Insert the splice to the bottom of the sealant filled tube. Fig. 3
6. Position wires into wire channels.
7. Wipe any sealant around opening and conductors.
8. Close lid ensuring latch is secured. Fig. 4

To be sold only with installation instructions.

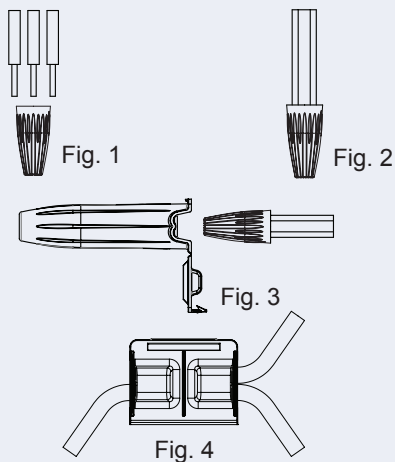

DBR/Y-600 Direct Bury Silicone Filled Tube with Strain Relief with Red Yellow Gorilla Nut

Catalog #	Selling Unit
20230	Bag of 2
20235	Box of 100

PRODUCT SPECIFICATIONS AND MEASUREMENTS

Max. Voltage: 600V max. building wire
(1000V max. signs or luminaries)
Connector Size: 3 11/16" x 1 1/2" x 1 3/16"
Wire Type: Copper/Copper
Wire Range: Min #22/Max #8
Temperature Rating: 105°C (221°F)
Silicone Sealant Temperature: -45°F to 400°F
Tube Construction: Sunlight and Impact Resistant Blended Polypropylene
UL Designation: GT2

Measurements (Inches):

A - 3.67
B - 1.18
C - 1.50

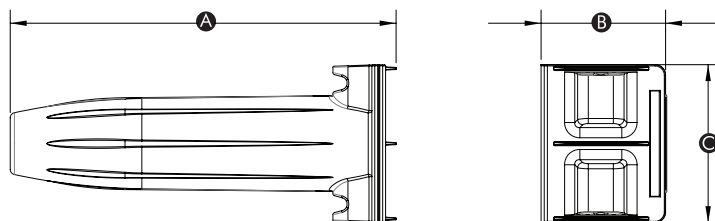

* UL 486D Listed as a sealed wire connector system. For use in damp, wet, raintight, direct bury and submersible locations. Not to be used in continuous submersion applications.

Selected 600V Wire Combinations

2-3 #10	2#18
2-5 #12	1 #8 w/2 #18
2-5 #14	3 #10 w/1 #18
4-6 #16	3 #12 w/3 #18
3 #14 w/2 #18	

Contact factory for a complete list of wire combinations at 800.633.0232.